



ET18

Compact Excavators < 6 t



ET18 – The evolution of your working world.

Wacker Neuson sets new standards for compact excavators with its new generation of models in the 1.7 through 2.4 t class. Tried and tested innovations are retained and combined with completely new development approaches. The result: A comprehensively renewed machine class right down to the finest details, which promises greater efficiency and performance.

- Innovative, newly designed cab: The redeveloped cab of the ET range sets new standards in terms of clear layout, safety and user comfort with its completely redesigned interior.
- Powerful and efficient performance: The big diesel engines and new, innovative hydraulic system set new standards of operation.
- Maximum connection facilities with up to 4 auxiliary control circuits: Up to 4 additional control circuit options are available ex-works for all models of the ET range.
- Every ET model has its own, optimized undercarriage to guarantee maximum stability and superior drive characteristics in tough everyday conditions.
- Every ET model has its own, optimized boom system with different dipper stick lengths: Thanks to the strong boom system with a choice of two optional dipper stick lengths, every machine achieves maximum digging strength and excavation values.



Technical specifications

Operating data

Shipping weight min.	1,610 kg
Operating weight min.	1,745 kg
Biting force max., acc. to ISO 6015	11.59 kN
Breakaway force max., acc. to ISO 6015	1,857 daN
Digging depth	2,100 mm
Dumping height max.	2,500 mm
Digging radius	3,800 mm
L x W x H min.	3,800 x 990 x 2,290 mm

Engine / Motor

Engine / Motor manufacturer	Yanmar
Engine / Motor type	3TNV76
Engine / Motor	Water-cooled 3-cylinder diesel engine
Displacement	1,116 cm ³
RPM / speed	2,200 rpm
Engine performance acc. to ISO	13.4 kW
Battery Voltage	44 Ah
Tank capacity	24 l

Hydraulic system

Duty pump	Double variable pump with 2 gear pumps
Flow rate max.	73 l/min
Operating pressure for working and traction hydraulics	200 bar
Operating pressure Slewing gear	125 bar
RPM / speed Superstructure	10 rpm
Hydraulic oil tank Contents	19 l

Wheel set

Travel speed max.	5.3 km/h
Gradeability max.	58 %
Chain width	230 mm



Ground clearance Standard undercarriage	210 mm
Dozer Blade	
Width	990 mm
Height	230 mm
Stroke Standard dozer blade above ground	200 mm
Stroke Standard dozer blade below ground	320 mm
Sound level	
Sound level (LwA) acc. to 2000/14/EC	93 dB(A)
Cabin - specified sound pressure level LpA acc. to ISO 6394	77 dB(A)



Dimensions

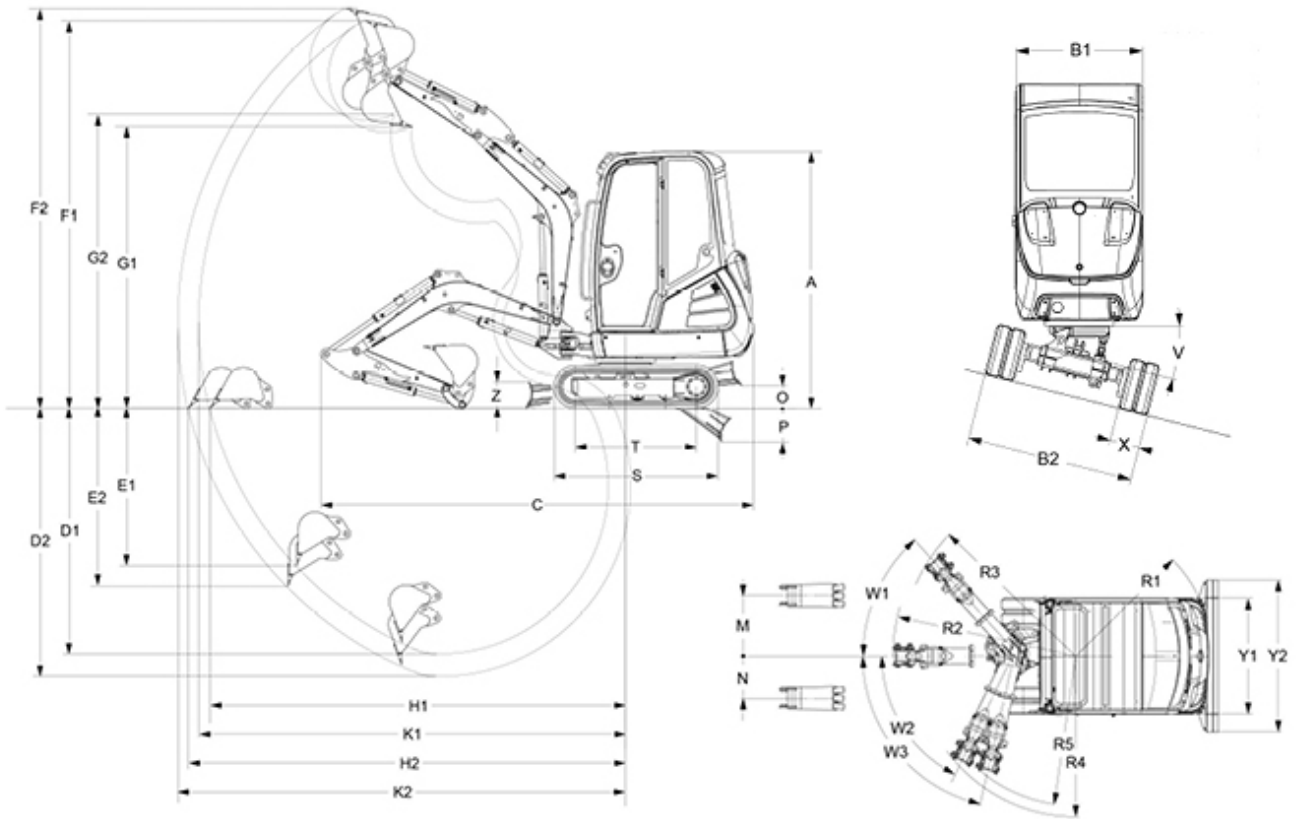

A	Height	2,290 mm
B1	Width Superstructure	990 mm
B2	Width undercarriage retracted	990 mm
B2	Width undercarriage extended (telescopic undercarriage only)	1,300 mm
C	Transport length	3,855 mm
D1	Digging depth Max. (short dipper stick)	2,200 mm
D2	Digging depth Max. (long dipper stick)	2,400 mm
E1	Insertion depth Max., vertikal (short dipper stick)	1,420 mm
E2	Insertion depth Max., vertikal (long dipper stick)	1,610 mm
F1	Insertion height Max. (short dipper stick)	3,450 mm
F2	Insertion height Max. (long dipper stick)	3,560 mm
G1	Dumping height Max. (short dipper stick)	2,500 mm
G2	Dumping height Max. (long dipper stick)	2,620 mm



K1	Digging radius Max. (short dipper stick)	3,800 mm
K2	Digging radius Max. (long dipper stick)	4,000 mm
H1	Range Max. ,on the ground (short dipper stick)	3,700 mm
H2	Range Max. ,on the ground (long dipper stick)	3,900 mm
R1	Rear swivel radius Min.	1,160 mm
M	Arm displacement Max. , to centre of bucket, right side	520 mm
N	Arm displacement Max. , to centre of bucket, left side	360 mm
O	Lift height Max., of dozer blade above ground (short)	200 mm
O	Lift height Max., of dozer blade above ground (long)	300 mm
P	Scraping depth Max., of dozer blade below ground (short)	320 mm
P	Scraping depth Max., of dozer blade below ground (long)	380 mm
R2	Boom slewing radius centre	1,580 mm
R3	Boom slewing radius right	1,500 mm
R4	Boom slewing radius left lock	1,380 mm
R5	Boom slewing radius left max.	1,280 mm
S	Length Total crawler length (standard undercarriage)	1,460 mm
S	Length Total crawler length (telescopic undercarriage)	1,605 mm
T	Length Crawler length Sprocket wheel (standard undercarriage)	1,080 mm
T	Length Crawler length Sprocket wheel (telescopic undercarriage)	1,225 mm
W1	Turning angle Max. of boom system to the right	48 °
W2	Turning angle Max. of boom system to the left lock	64 °
W3	Turning angle Max. of boom system to the left	77 °
X	Chain width	230 mm
Y1	Width Dozer blade	990 mm
Y2	Width Dozer blade width with extension (telescopic undercarriage only)	1,300 mm
Z	Height Dozer blade	230 mm

Please note

that product availability can vary from country to country. It is possible that information / products may not be available in your country. More detailed information on engine power can be found in the operator's manual; the stated power may vary due to specific operating conditions.

Subject to alterations and errors excepted. Applicable also to illustrations.

Copyright © 2015 Wacker Neuson SE.