

DW20

Wheel Dumpers



**WACKER
NEUSON**
all it takes!



Perfect for off-road and easy to handle

This dumper in the compact class of up to 2t payload convinces with a hydrostatic all wheel drive and the articulated pendulum joint which is typical for Wacker Neuson wheel dumpers. A high ground clearance for off-road mobility and the all-wheel drive make the DW20 the perfect partner on the job site. The DW20 can be ordered with an asphalt skip for special applications requiring a lower dumping height. The optionally available swivel tip skip with self-loading device also allows completely independent operation on the construction site. Further skip variants complete the wide range of applications. The design of the DW20 offers an optimum view of the skip.

- Just take a seat and drive: With the hydrostatic all-wheel drive, the driver can concentrate on his work without having to change gears frequently. A constant tractive force from 0 to maximum speed and the hydrostatic braking complete the pleasant driving experience.
- The articulated pendulum joint adapts to any unevenness on the construction site and remains stable in any situation.
- The all-wheel drive provides a high level of safety also when working on uneven terrain at full load.
- The very clear dashboard provides pleasant operation and quick access to all elements. The joystick combines many functions in a single action: skip control, change of

gear and direction of travel.

- The spring-loaded parking brake is wear-free and therefore extremely durable. It is actuated automatically as soon as the engine is switched off, without any additional effort.

DW20 Technical specifications

	Front Tip Skip	Swivel Tip Skip	Self-loading Device	Low Skip
Operating data				
Payload kg	2,000	2,000	2,000	2,000
Shipping weight kg	1,899	2,034	2,389	2,019
Operating weight kg	2,005	2,140	2,495	2,125
Skip capacity leveled l	1,200	950	780	950
Skip capacity heaped l	1,500	1,280	1,060	1,160
Skip capacity liquid measure l	950	700	630	740
Engine / Motor				
Engine / Motor manufacturer	Yanmar	Yanmar	Yanmar	Yanmar
Engine / Motor type	3TNV76	3TNV76	3TNV76	3TNV76
Engine / Motor	Diesel	Diesel	Diesel	Diesel
Engine performance acc. to ISO 3046/1 kW	18.9	18.9	18.9	18.9
Displacement cm ³	1,116	1,116	1,116	1,116
Engine RPM rpm	3000	3000	3000	3000
Travel speed km/h	20	20	20	20
Articulation angle °	36	36	36	36
Pendulum angle °	15	15	15	15
Turning radius mm	3,700	3,700	3,700	3,700
Tires	10.0/75-15.3 Mitas TS-05	10.0/75-15.3 Mitas TS-05	10.0/75-15.3 Mitas TS-05	10.0/75-15.3 Mitas TS-05
Fuel tank capacity l	35	35	35	35

DW20 Dimensions

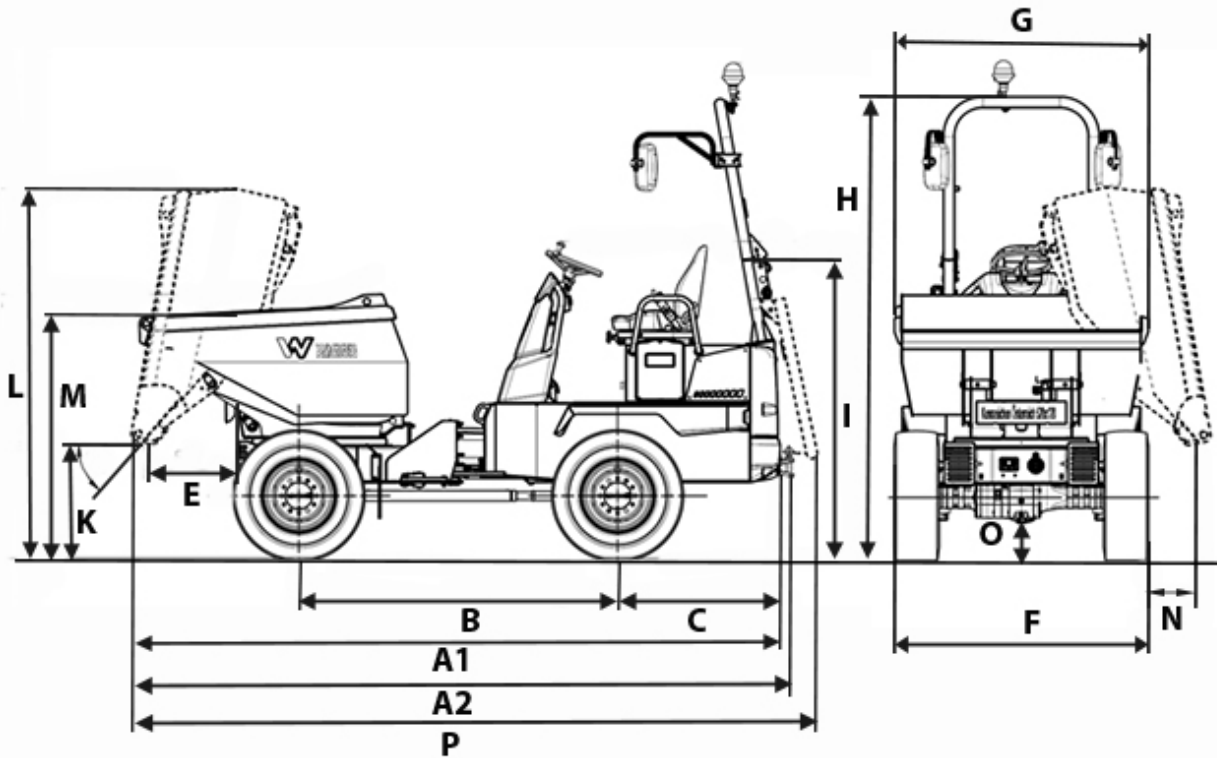

		Front Tip Skip	Swivel Tip Skip	Self-loading Device	Low Skip 2.2 m
A1	Overall length	3,710 mm	3,706 mm	3,735 mm	3,788 mm
A2	Overall length with hitch	3,788 mm	3,784 mm	3,813 mm	3,865 mm
B	Wheelbase	1,882 mm	1,882 mm	1,882 mm	1,882 mm
C	Rear overhang	963 mm	963 mm	963 mm	963 mm
E	Dumping distance	649 mm	481 mm	457 mm	527 mm
F	Width	1,497 mm	1,497 mm	1,497 mm	
G	Skip width	1,490 mm	1,482 mm	1,462 mm	1,488 mm
H	Height ROPS	2,738 mm	2,738 mm	2,738 mm	2,738 mm
I	Height ROPS tilted	1,770 mm	1,770 mm	1,770 mm	1,770 mm
K	Dump height max.	193 mm	910 mm	881 mm	675 mm
L	Skip height skip tilted	2,034 mm	2,855 mm	2,862 mm	2,187 mm
M	Skip height	1,433 mm	1,404 mm	1,388 mm	1,430 mm
N	Dumping distance lateral		241 mm	263 mm	290 mm
O	Ground clearance	217 mm	217 mm	217 mm	217 mm
P	Length ROPS tilted	3,927 mm	2,923 mm	3,952 mm	4,004 mm
--	Dump angle	48 °	48 °	48 °	49 °

Please note: that product availability can vary from country to country. It is possible that information / products may not be available in your country. More detailed information on engine power can be found in the operator's manual; the stated power may vary due to specific operating conditions. Subject to alterations and errors excepted. Applicable also to illustrations.
Copyright © 2019 Wacker Neuson SE.